



## Fire, Cause & Origin of Heavy Vehicles: Mechanical & Forensic Methods

FIRE INVESTIGATION

BY CHRISTOPHER W. FERRONE

*The occurrence of large-scale fires involving heavy vehicles and equipment remains a problem.*

The occurrence of large-scale fires involving heavy vehicles and equipment remains a problem. Methods must be developed to determine the cause and origin of these fires. A method combining mechanical engineering, basic mechanics along with forensic techniques and investigation standards has been developed, in a single source format, to assist in determining the cause of large-scale fires. Techniques used in the overall method are the machine's mechanical and electrical function, the scenario of facts, operational profile, prior maintenance, the construction of the machine and reconstruction of the accident. This article uses individual case study examples to illustrate the techniques to be used in the analysis.

Heavy trucks and equipment are expensive and perform valuable work tasks. A fire can occur on a heavy truck or piece of equipment for many reasons. Unlike automobiles, they are sophisticated vehicles with many subsystems. The author has investigated fires for more than 20 years. Throughout this experience, a consistent pattern of data has been collected. If the vehicle is in motion (driving or idling), certain items are valid as possible causes. Likewise, if the vehicle is stationary, (engine on or off) other items become potential causes. In either case, the situation is dangerous and costly in both human life and property (Photos 1 and 2).

### COMMON CAUSES

The common causes discussed in this article are not ranked in order of likelihood. Vehicle operational profile, maintenance care, vehicle history and reconstruction help determine which could be the origin of the fire. Some common causes discussed include

- alternator;
- starter;
- fuel/combustible materials;
- hubs/bearings;
- brakes (disc/drum);
- tires;
- turbocharger;
- sensors/transducers;
- auxiliary power units APUs;
- 2007 emission schemes;
- batteries/cables/distribution/electrical system;
- chassis/vocation-related components.

### WHAT IS REQUIRED FOR A FIRE

Air, a combustible material and an ignition source are the three elements needed to create a fire. These three items form what is known as the Fire Triangle (Figure 1). If any one of these elements is not present, a fire cannot occur.

Air is all around us, making for an abundant supply of the first element. A combustible material, the second element, is anything that may be present on the truck, such as diesel fuel, power steering fluid, engine oil, transmission fluid, gear/hub oil, grease, tires and wire/cable insulation.

Photo 1: (right) Fuel tanker near bridge to Florida Keys.

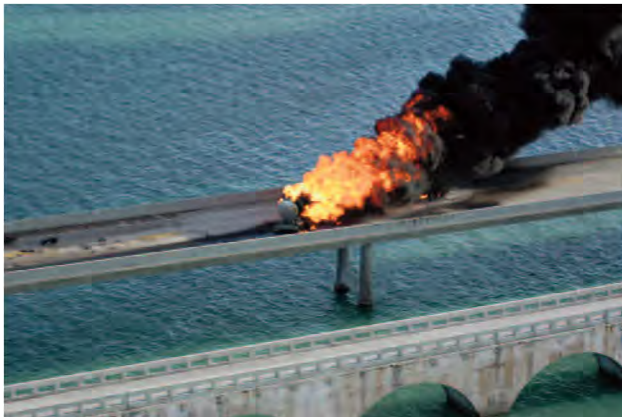
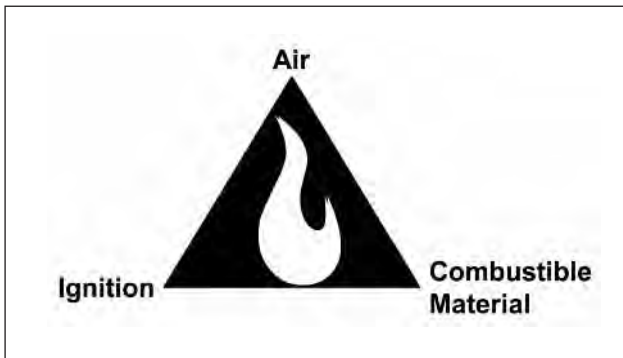

Photo 2: (far right) 1 million lb G.V.W.R. mining truck.



The third element, the ignition source, can come in many forms. An open flame, a sustained duration spark and auto-ignition are the most common ignition sources (Auto-ignition is defined as the ability to ignite a flammable substance in the absence of an open flame or sustained duration spark. This phenomenon is created solely by the surface temperature of an object.). Therefore, separating the ignition

## Figure 1 Fire Triangle



## Figure 2 Atomization

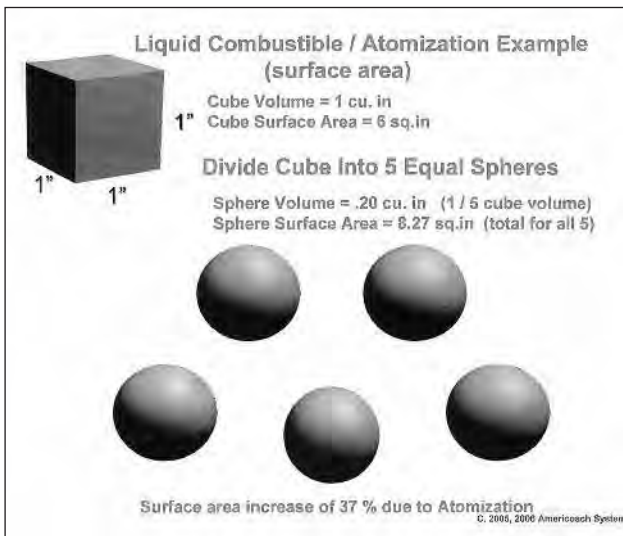

Photo 3: Burn pattern.

source(s) from the combustible materials, to the extent that it can be, is good design practice. Along with the completion of the fire triangle, atomization of the liquid must occur to satisfy the stoichiometric requirements (14:1) to burn. Absent this proper air-to-fuel ratio, the substance is deemed too rich to burn and will not ignite.

Atomization increases the surface area of the liquid by creating small spheres or droplets. By taking a cube of one cubic inch in volume and dividing it into five equal spheres, each 1/5 of 1 cubic inch, the total surface area of the five spheres is 37% more than the surface area of the original same volume of one cubic inch (Figure 2). This increase in surface area is what allows the air to properly mix with the liquid for the stoichiometric ratio to be satisfied.

For example, this atomization usually comes from a spraying of the liquid from a pressurized pinhole leak in a hose or component housing or even a breached fuel tank or line. Once this ratio has been met, a fire can occur.

### TEMPERATURE MAPPING

Temperature mapping is a technique used to determine the surface temperature of various components on the truck or equipment. Temperature mapping can be done by taking component temperatures immediately after the vehicle has been operating under load, during loaded operation or on a chassis dynamometer. By using a noncontact laser thermometer, a map of component surface temperatures can be established for any particular vehicle within the engine compartment.

This study verifies individual component surface temperatures to assist in the cause and origin analysis, as well as fire prevention through design. Certain components are normally at the auto-ignition temperature of the onboard fluids and some are not. What can be taken from the temperature map is that if the “cooler” components are functioning normally, they cannot be an auto-ignition source. If a fire was to be traced back to a cooler component, such as a drive axle hub, that would indicate that this component experienced some type of mechanical failure, which preceded the fire and became the triggering element—the ignition source. In summary, the cool components cannot become an ignition source without experiencing a localized failure due to the fact that their normal operating (surface temperature) is less than the average (onboard fluid/combustible) auto-ignition temperature.

### DAMAGE PATTERN ANALYSIS

This analysis involves the observation of flame/heat damage patterns leading to the origin of the fire (Photo 3). The technique is generally comprised of the elements shown in the flowchart (Figure 3) and come from NFPA 921. This method is further facilitated by reassembling the truck (as much as possible) to show configuration and component placement (Photo 4).

## Figure 3 Damage Pattern Analysis

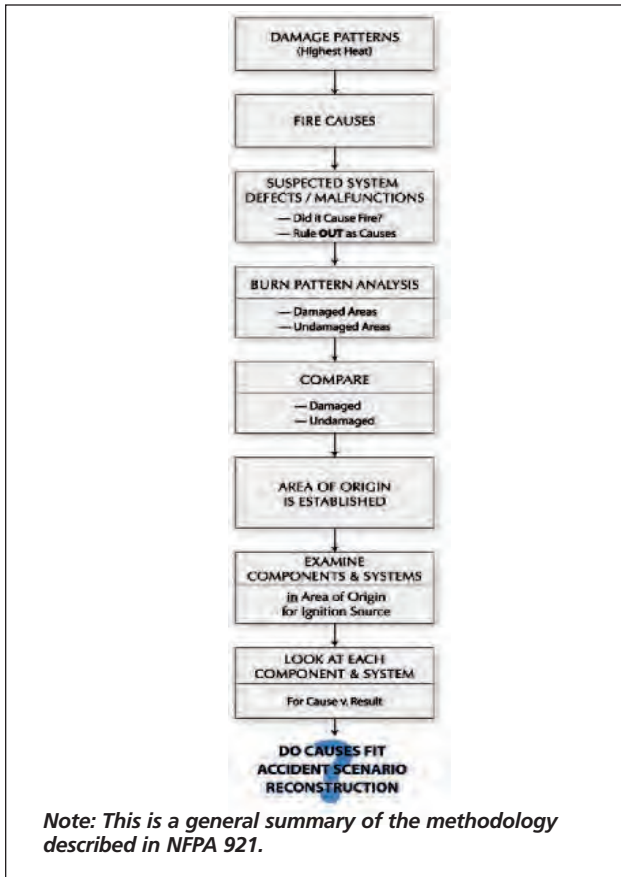

Photo 4:  
Reassembling  
components.



Photo 5: (right)  
Turbocharger with  
impact damage.



Photo 6:  
(far right)  
Turbocharger with  
impact damage  
showing  
rough edges.



By following this basic process, investigators can begin to focus on elements that may have led to the beginning of the fire. However, throughout this process, a high-level understanding of the components and systems functional behavior must be known to the investigator.

### PROCESS OF ELIMINATION

In many fires, the origin evidence is burned. This leaves the investigator with a difficult task. A competent method of analysis, if left with this situation, is to systematically eliminate ignition and combustible sources one by one using observations, mechanical function, system logic and reconstruction. Each component listed in the common causes section should be evaluated. For example, Photograph 5 shows the truck engine at the accident scene with the dual turbochargers off the engine. Photograph 6 shows rough edges on the turbocharger connection indicating a traumatic impact failure. Therefore, since these turbochargers were knocked off the engine in the accident phase and reside on the nonfuel side of the engine, they are not likely a candidate as an ignition source.

### Fires With Engine Off

Fires can start with the engine off and after an extended period since the shutdown. When these facts are present, the investigator should focus on ignition sources that are (B+) with the ignition in the off position, specifically, items which are (B+) energized all the time, regardless of ignition position. These include battery cables; batteries; brake booster motors; alternator; starter; master power distribution to cab; an anything wired (B+).

Items that are energized by the vehicle's ignition circuit are (normally) not an ignition source with the ignition in the off position. Therefore, they can be eliminated during the analysis.

### Alternator

For most applications, the charging system for the truck/tractor produces 160 amperes or more. With this, the alternator (and system) carries great potential as an ignition source. During normal operation, the alternator produces anywhere from 12 to 18 volts (12-volt system) and 24 to 32 volts (24-volt system). This is accompanied by amperage ratings from 160 to 300 amps. Positive



Photo 7: Causal alternator.

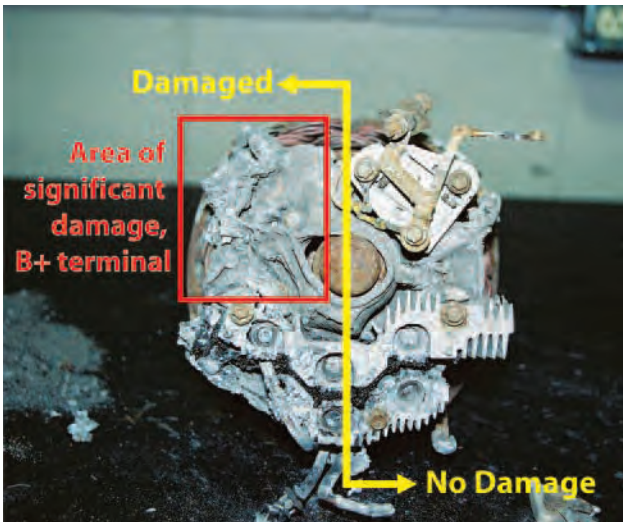

Photo 8: Artifact alternator.

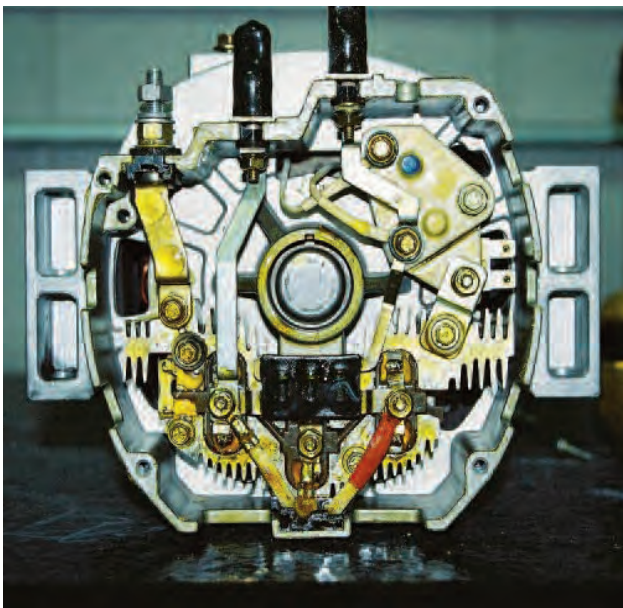

Photo 9: Exemplar alternator.

(B+) and negative cable connection condition is vital for safe operation.

In some instances, a fire has begun with the vehicle's engine off and after some period of time since the most recent engine shutdown. This can be attributed to an internal alternator failure, in some instances a diode failure. Diodes act as a one-way check valve for current. Typically, if a diode fails in this scenario, positive (B+) battery voltage/current goes to ground and has been known to start a fire (Photos 7, 8 and 9).

Photo 7 shows an alternator that was determined to be the cause of this fire. Photograph 10 shows the alternator of a truck parked next to the truck in Photo 7, however, with completely different appearances despite being involved in the same fire only a few feet apart.

The alternator in Photo 7 was found on the ground next to the truck. When it was picked up, it had created an unburned area on the floor. This indicates that it fell to the ground before anything else fell on that spot and covered the floor in that area. The solution to this potential fire scenario is to park the truck with the main battery switch off. This will disconnect the batteries from the alternator eliminating this potential.

#### Remote Jump Post

With some applications, a convenience feature is provided in the engine compartment, mounted to the frame rail or battery box for "jumping" a disabled vehicle. This is typically a positive (+) cable running from the starter or battery to an exposed stud. These connections must be inspected and maintained to provide integrity. Additionally, this stud is covered with a flexible rubber boot (Photo 11).

This boot must be in good condition and over the positive (+) stud at all times. A loose jumping stud/cable, or if it is contacted during a collision, can create a sustained duration high-energy spark (Photo 12).

#### Starter

Heavy trucks use a variety of starters, such as Delco, Mitsubishi, Prestolite and Leece-Neville. Under normal



Photo 10: Noncausal alternator.



Photo 11: Remote jump posts.

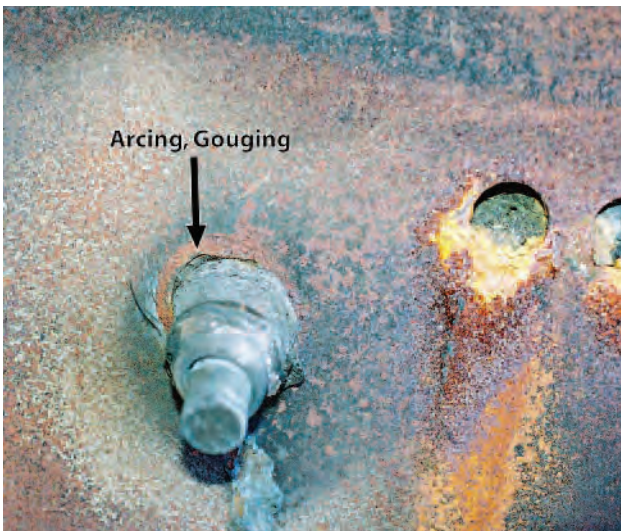

Photo 12: B+ jump post, battery box.



Photo 13: Hub failure/tire fire.

circumstances, the starter draws 800 to 1,000 amps while cranking the engine. When it is not cranking the engine (no current flow), it is exposed to battery voltage. As with the alternator, the starter is connected to the batteries via a B+ (direct battery feed) cable. It, too, is routed to a stud on the starter motor. Care must be given to the cable condition, cable-to-starter connections, as well as its routing so that this B+ cable is not making unwanted contact and potentially coming in contact with ground as a result of an insulation breach.

The starter should be treated and cared for in the same manner as the alternator since it resides on the fuel side of the engine in some applications.

### Combustible Materials

In some cases, the onboard fuel supply can be a causal element in a fire. For the fuel to ignite, the surface temperature of the engine and related components must be at least at the auto-ignition temperature of diesel fuel, and a high-energy sustained duration spark or open flame must be present.

All of the liquids, fuel, power steering fluid, engine oil and hub/gear oil, found on a heavy truck or piece of heavy equipment have an auto-ignition temperature (Figure 4).

If one or more of these fluids/combustibles were to come in contact with a sufficiently hot surface at auto-ignition temperature, that fluid/combustible would ignite in the absence of an open flame. To minimize fluid fires, all hoses, housings, couplings, fittings and filters must be inspected diligently to reduce or eliminate leaks, which could lead to a fire.

The first step is to regularly clean the engine, transmission and interior surfaces of the engine compartment. This has a triple advantage to the operator. First, oil and road dirt covering the engine will act to insulate it, holding in engine heat. Second, when the engine is clean, it is easier to locate a fluid leak. Lastly, with a clean engine, the risk of fire and it spreading by virtue of not having any combustible materials on the engine itself are reduced. Investigators should observe flame/heat patterns in the engine compartment/room as a further cause and origin method.

### Hub Failure

Wheel hubs low on oil can have an elevated operating temperature high enough to ignite the surrounding combustible materials (hub oil and tires) by auto-ignition. Coincident to this, in some cases, is a wheel end failure resulting in a “wheel-off” situation. Typically, the outer wheel bearings’ lowest point is above the lowest point of the hub seal. Therefore, since the outer bearing is at that elevation, it starves for oil first.

The inner bearing is at a lower point in the hub and is usually bathed in oil for a longer period of time. Two common failure modes for the hub (non-driving) to be low on oil are hubcap failure and seal failure. The hubcap can have at least four failure modes; the

## Figure 4 Combustible Materials

Auto-Ignition Temperatures in F°/C°	
Onboard Fluids	Temperatures
Diesel Fuel	446°/230°
Power Steering	417°/213°
Engine Oil	449°/231°
Transmission Fluid	417°/213°
Transmission Gear Oil	730°/387.8°
Coolants (50/50)	903°/483°
Hub/Gear Oil	428°/220°
Tires (smoldering)	450°-500°/232°-260°

Note. These are examples only and do not represent all types and varieties of fluids.

Flash Points in F°/C°	
Onboard Fluids	Temperatures
Diesel Fuel (1-D)	100°/37.8°
Diesel Fuel (2-D)	125°/51.7°
Diesel Fuel (3-D)	130°/54.4°
Gear Oil	369°-580°/187.2°-304.4°
Engine Oil	420°-485°/215.6°-251.7°
Power Steering Fluid	365°-450°/185°-232.2°
Transmission Fluid	399°-453°/203.9°-233.9°
Coolants (50/50)	230°-270°/None-110°

Note. A flash point is the lowest temperature at which the vapor of a combustible liquid can be ignited in the air. These are examples only and do not represent all types and varieties of fluids.



Photo 14: Deformed bearing rollers.

plastic site glass, o-ring, the rubber plug and the mounting gasket. For any of these reasons, the hub can become low on oil. As for a drive hub, the axle flange gasket or seal can be a leak point allowing the hub to become low on oil. When the seal wiper becomes worn (grooved), it may create a leak point despite the seal's integrity. The wiper should be inspected each time the hub is removed and changed if it appears to be excessively worn.

In some cases, during a wheel bearing failure, the vehicles' ABS dash light may become illuminated as a result of the sensor-to-hub gap becoming greater due to the hub beginning to come off of the spindle or axle tube, a skidding or locked tire/wheel or a unitized wheel end failure. The ABS control module can, in some cases, be downloaded after the incident to determine whether or not the ABS system detected a failure prior to the fire, such as a skidding tire due to a bearing failure. This information can assist in cause and origin determination.

Photo 13 shows a burned trailer, which experienced a hub failure. This failure was caused by low hub oil level. This condition ultimately led to the fire, which started at the tire. This is indicated by the deformed (melted) bearing rollers (Photo 14). Bearing rollers with this appearance can only occur when the hub oil level is low. This deformation cannot occur due to the fire. Low hub oil levels create extremely high heat (Photo 15). The weight of the load that the bearing supports creates pressure on each bearing roller. This pressure coupled with the extreme heat creates the rollers deformation. Once this occurs, the tire(s) near this area can ignite.

An additional hub failure risk exists, with disc brake applications, during a wheel bearing/hub failure. That is, as the outer bearing begins to fail, the hub load is transferred from the outer bearing to the brake caliper, brake pads and rotor. Once the outer bearing has failed completely, no longer able to support the hub load, the caliper, brake pads and rotor are then supporting that particular wheel end (Photos 16, 17). This is due to the fact that the caliper rides in the caliper carrier, which is attached to the spider (torque plate) that is mounted to the axle tube/spindle (Figure 5).

Once the brake caliper begins carrying the load at that particular wheel end, the surface temperature of the brake pads and rotor (or drum) rise well above the auto-ignition temperature of the surrounding combustibles (due to friction) eventually igniting them. The combustible material typically ignited by this failure mode is the tire(s). This concept of brake caliper/pad/rotor supporting the hub load can typically be seen by nonparallel brake pad contact surfaces. As a result of this temporary load support from the caliper, the operator may continue to drive the vehicle without any indication of a problem until it is too late.

### Disc Brakes

A "frozen" disc brake caliper can generate enough heat to ignite the surrounding combustible materials and

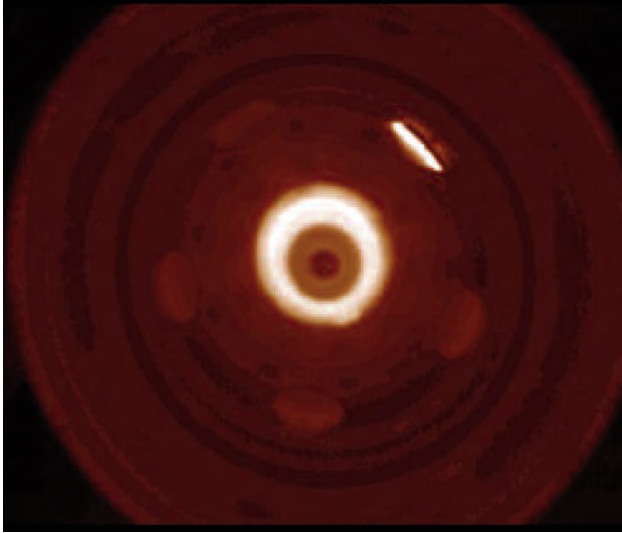

*Photo 15: Thermal scan of an overheated wheel bearing.*



*Photo 16: Causal disc brake/wheel end failure.*



*Photo 17: Non-causal disc brake/wheel end.*

sustain a fire. Proper inspection and lubrication intervals (if applicable) should be adhered to along with a periodic activation and release sequence confirming that the caliper is releasing and allowing the rotor to turn freely. This scenario applies to both air and hydraulic disc brakes. A simple method to determine the proper action of the caliper is to insert a feeler gauge (.002 in. to .004 in.) between the brake pad and rotor. By applying the service brakes, a technician can feel if the gauge goes into this space, remains there upon brake application and is then released upon release of the service brakes.

### **Drum Brakes**

Drum brakes can create a fire hazard similar to disc brakes by supporting the hub load during a bearing failure or by a partial application (stuck) brake. Specifically, if the brakes are applied during vehicle motion, through either the service or parking system, they can create enough friction, leading to extreme heat, that they can cause a tire fire or ignite some other combustible material (Photo 18). Over the last 20 years, engine manufacturers have continually produced engines with high horsepower and torque ratings. These high-output engines are capable of driving through a partially applied service brake or fully applied parking brake. If this were to occur at highway speeds, enough frictional heat can be developed to start a fire (Photo 19).

Various pneumatic and mechanical issues can prompt a brake failure, which can lead to a fire. Generally speaking, when drum brakes approach this scenario, they leave signatures. Brake drums may show signs of rouging (Photo 20), and the matching brake blocks may show a burn pattern if not damaged by the fire (Photo 21). In the extreme case, the brake blocks can become fused to the drum as a result of the bonding agent (resin) of the brake blocks actually beginning to melt and burn (Photo 22).

### **Tires**

A flat or underinflated dual tire or single tire can have an elevated temperature and in some cases go undetected. Dual tires are spaced apart to provide a gap to prevent contact between the tires (Figure 6).

If the adjacent tire is underinflated, the gap closes and the tires begin to “kiss.” Since an underinflated tire only bulges at the road surface, a cyclical contact event occurs between the inflated tire and the underinflated tire. Over time, this cyclical contact may generate heat, increasing the tire’s temperature.

Therefore, operators should always ensure that all tires, especially dual tires, are inflated and not in contact with one another. In general, operating temperatures for radial tires can be anywhere between ambient plus 60 °F (150 °F to 180 °F). Under severe conditions, the operating temperatures will range in the 200 °F area (Auto-ignition is defined as the ability to ignite a flammable substance in the absence of an open flame or sustained duration spark. This phenomenon is created solely by the

## Figure 5 Disc Brake/Spindle End

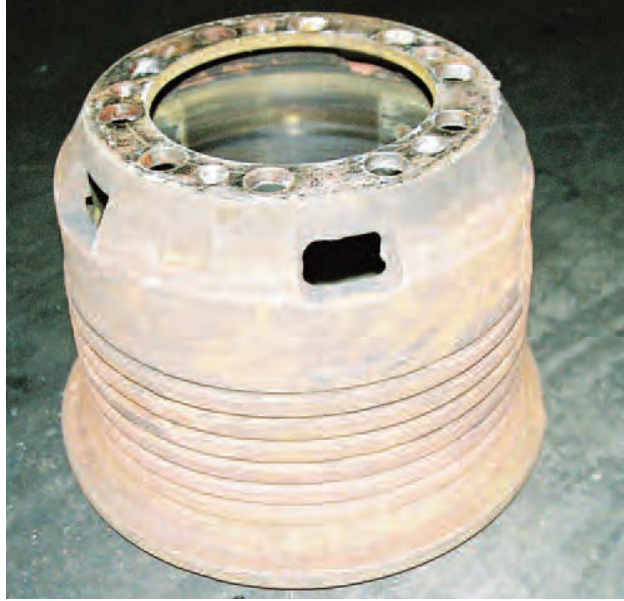
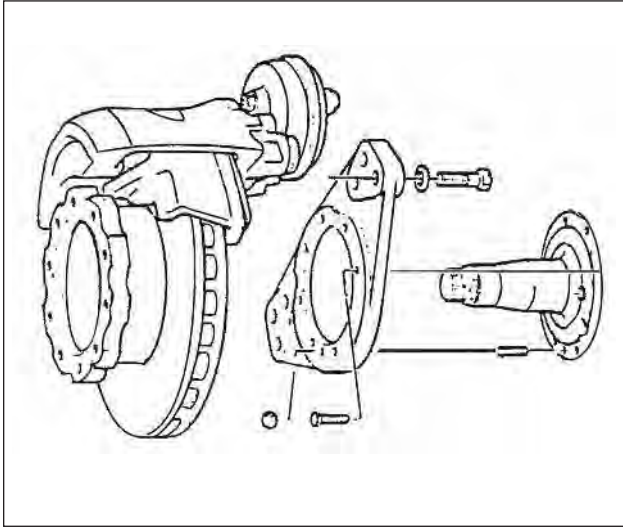

Photo 20: Brake drum rouging caused by overheating.

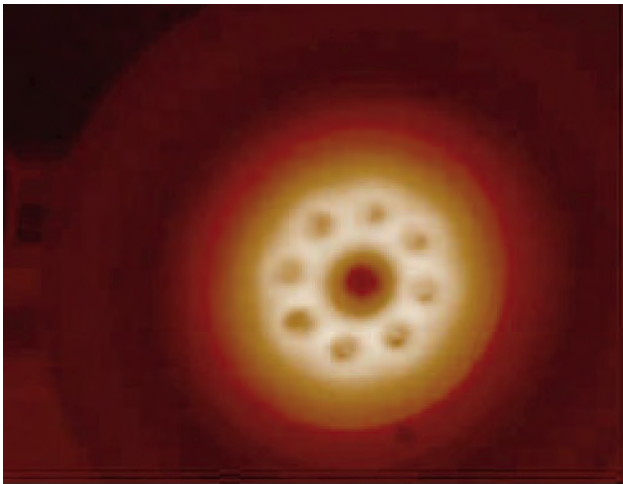

Photo 18: Thermal scan of overheated brake drum.

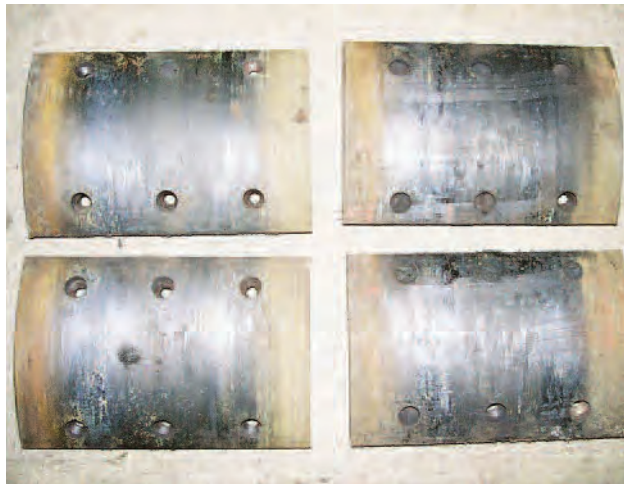

Photo 21: Drum brake; brake blocks overheated.



Photo 19: Tire fire started by dragging parking brake.



Photo 22: Fused brake block



## Figure 6 Sectional View of Dual Tire

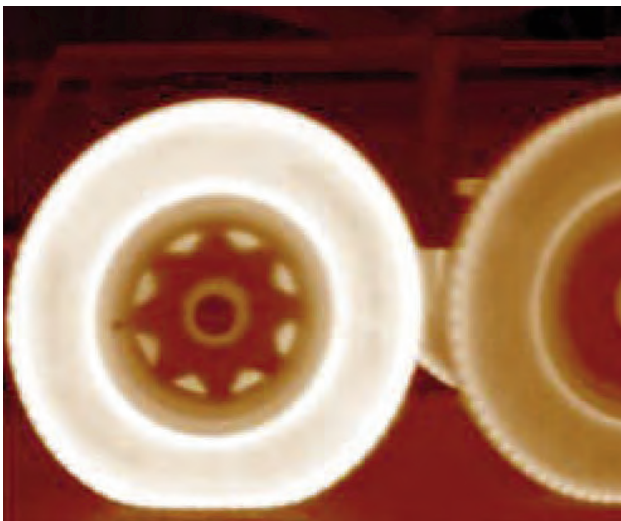
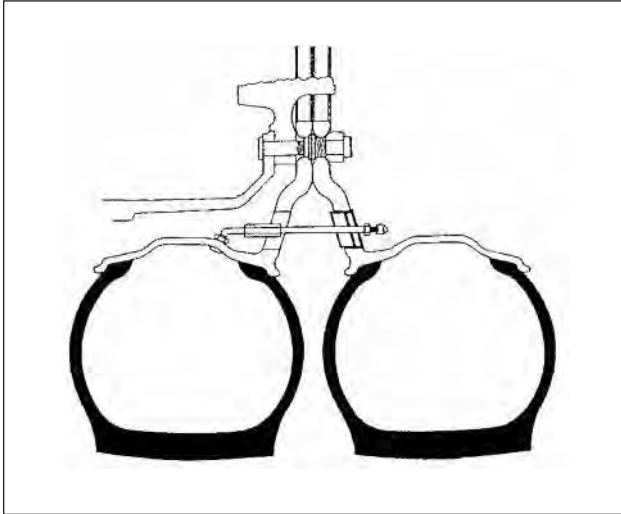

*Photo 23: Thermal scan of overheated tire due to low inflation pressure.*



*Photo 24: Straight tire cords indicating no rotation at time of fire.*

surface temperature of an object.) (Photo 23). Tires generally revert (melt) at approximately 250 °F and catch fire over the 600 °F mark. It is common, although not mandatory, for the tire fire to occur when the vehicle comes to a stop. This is the condition with the least amount of air flow circulating around the brake rotors, brake drums and tires. Without air flow around these items, their temperature rises rapidly and is transmitted to the tire—subsequently igniting it.

Tires, which have ignited during (rotation) travel, can be indicated by the disturbance or twisting of the tire reinforcing cords. Tires that have ignited while stationary (no rotation), have tire cords, which remain largely undisturbed (Photo 24). In general, tires do not become a fire hazard on their own. In most cases, it takes a localized failure of an adjacent component to ignite the tire(s).

### **Turbochargers**

Turbochargers are a dual threat as an ignition source. First, since they are typically very hot on the surface, they can act as an auto-ignition source. Second, upon their own internal failure, they can become an ignition source by virtue of their own internal lubrication oil. The typical turbocharger supports the shaft of the compressor and turbine with a nonconventional bearing. This is unlike the typical roller bearing. Instead the shaft is supported by two bearing collars, which are supported by the boundary lubrication layer (Figure 7).

Upon a failure of this bearing system or an imbalance of either the turbine or compressor wheels, contact is made within the turbocharger housing, causing a rapid deterioration of the compressor and turbine (Photo 25). Once the shaft has been reoriented, as a result of any one of the aforementioned failure modes, the shaft seal(s), which controls the lubrication oil within the bearing cavity, subsequently fails allowing oil to enter directly into the hot side (turbine) of the housing and then directly into the exhaust system (Figure 8). This can create an auto-ignition fire within the turbocharger itself or exhaust system.

Some engine manufacturers have reprogrammed engine management software to detect the symptom of this failure (The general methods used for this study were locate artifact elbow, recreate failure breach pattern on an exemplar elbow and pump water through the exemplar elbow to demonstrate fuel release.). The engine's electronic control module (ECM) monitors turbocharger boost pressure for performance and engine management control purposes. With the change in software, ECM now sets a fault code for low boost pressure, which could indicate an internally failed turbocharger.

However, if the engine in question precedes any recent software change, two other methods can be used to detect the onset of an internal turbocharger failure. If the turbocharger has experienced an internal failure, the performance of the engine is compromised. Specifically, blue smoke, due to oil consumption along with reduced engine torque will be noticed. Also a specific oil leak

from the waste gate pivot point can be observed (Photo 26). Once oil has begun to leak from this point on the turbocharger, it should be removed from service and the exhaust system should be thoroughly cleaned. To assist in preventing this failure mode, the turbocharger waste gate or variable geometry function (VGT) must be confirmed.

These two systems regulate turbocharger boost pressure. If they were to fail to regulate this pressure, it may lead to an internal failure, as a result of over-pressurization and/or overspeed, thus leading to a fire.

## Figure 7 Turbocharger, Exploded View

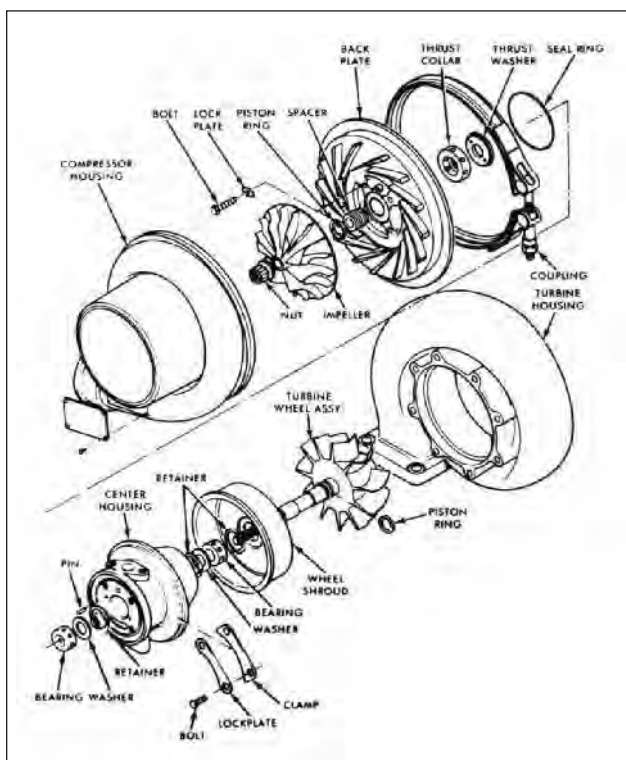

Photo 25: Failed turbocharger compressor.

Additionally, the shaft free play, both axially and radially, must be inspected by a mechanic.

### External Turbocharger Oil Lines

With most four-stroke cycle inline engine applications, the turbocharger has two oil lines that need to be periodically inspected (Photo 27). These turbochargers have an external supply and return oil line. In either case, a leaking oil line must be repaired to prevent an auto-ignition fire.

### Sensors/Transducers

In most applications, sensors are exposed to fuel, engine oil, transmission fluid and hydraulic oil, among others. These sensors are typically diaphragm type; that is to say an internal diaphragm is moved by the fluid pressure inside the sensor/transducers/switches. Since pressurized fluid enters these sensors/switches, it is vital that they be periodically inspected for leaks. Based on their position on the engine/transmission/component, they may become a source for a combustible fluid leak point, which may come in contact with an ignition source and initiate a fire.

### Auxiliary Power Units

Some heavy trucks use an auxiliary power unit (APU) to provide air conditioning, heat or electrical power while the engine is off (Photo 28). These must be inspected and analyzed to determine whether they are related to the fire. APU is similar to the truck's engine in that it has its own starter, alternator, fuel system, lubrication and electrical distribution system. Each of these items must be analyzed to determine if any were related to the fire. Additionally, APU can also be an auto-ignition concern and must be evaluated in that regard.

### 2007 Emissions Schemes

A growing number of 2007 engines with regeneration capability are entering the stream of commerce. The design suggests regenerating (cleaning) the particulate trap by elevating its temperature to burn off the material trapped inside. The regeneration process converts ash and soot, which is trapped in the diesel particulate filter (DPF), and converts it to carbon dioxide.

To do this, the engine must create exhaust gases with high enough temperatures to complete this process. In some designs, during regeneration, raw fuel is injected near the turbocharger, via a doser, increasing the temperature of the exhaust gases to 1,200 °F to 1,500 °F. As with any other component, with a high (>430 °F) surface

*A growing number of 2007 engines with regeneration capability are entering the stream of commerce. The design suggests regenerating (cleaning) the particulate trap by elevating its temperature to burn off the material trapped inside.*

## Figure 8 Air Intake Schematic

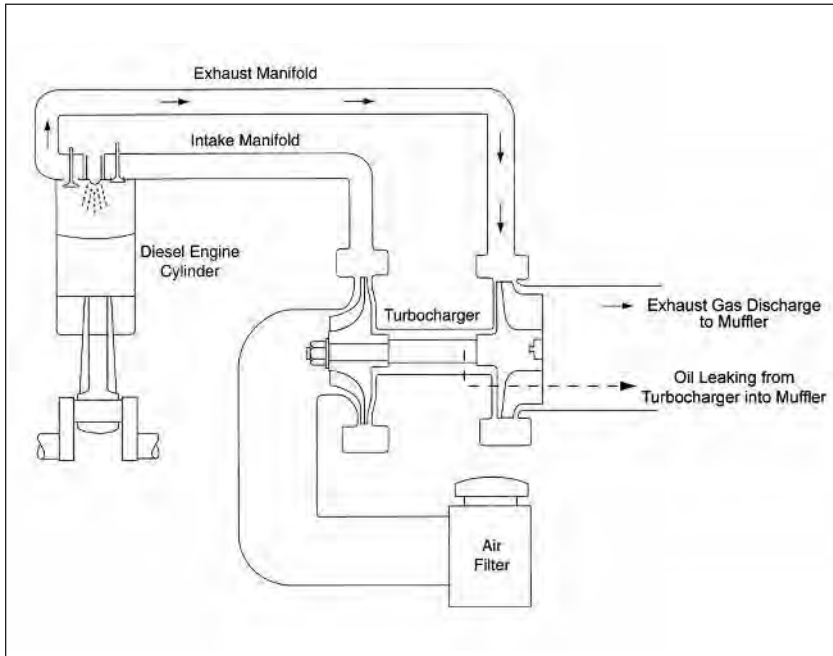

temperature, leaks in the immediate area must be repaired to avoid contact with this system while it is regenerating DPF. Lastly, this system's interlocks, which dictate when it can function, must be confirmed to be working to avoid a cycle of regeneration at an undesirable time or location.

### **Batteries/Cables/Distribution/Electrical System**

These elements of the electrical system carry and distribute the electrical power throughout the vehicle. Battery location, cable routing and securement, along with control elements, all have the potential to become ignition sources.

Battery location is an important design element within any vehicle. The placement of the batteries, in some cases, can be impacted in the collision phase of an accident. This

can lead to becoming an ignition source of a fire.

Cable routing and securement is usually a "packaging and housekeeping" item with respect to vehicle design. Cable routing and securement goes hand-in-hand. Loose, pinched, excessive length or breached B+ cables(s) can lead to a high-energy sustained duration spark, which can become an ignition source. For example, "balling," a term used to describe the physical appearance of a cable which has experienced a separation under power, is shown in Photo 29.

Cables that can be contacted during the collision phase of an accident can become an ignition source.

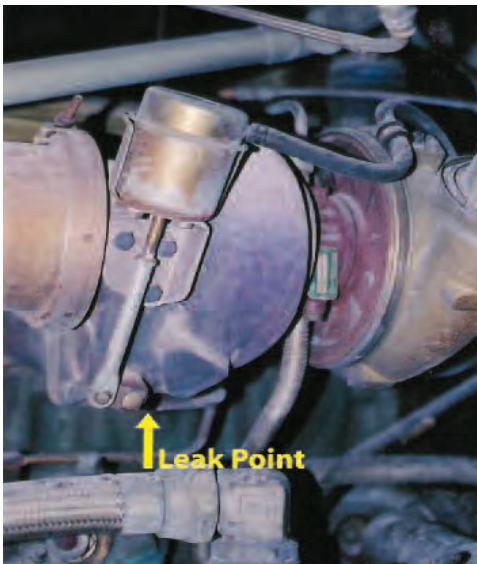

Photo 26: Turbocharger/waste gate.

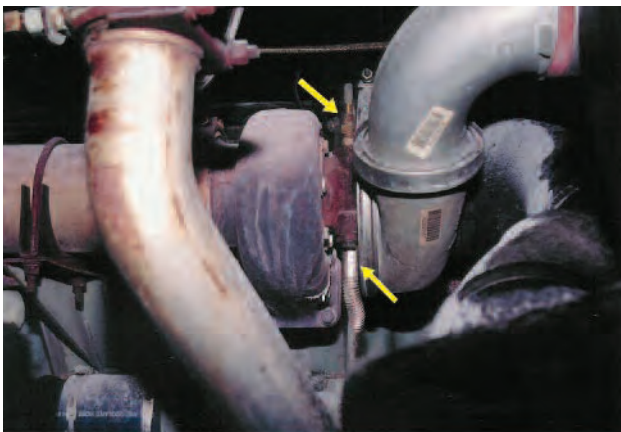

Photo 27: Typical turbocharger oil inlet/outlet lines.



Photo 28: Auxiliary power unit.

The securement of the cable(s), once routing is established, is vital to prevent the breaching of the insulation or the mechanical failure of a cable connector. In some cases, over time, a B+ cable can move cyclically enough that it will eventually make contact with chassis ground creating a sustained duration high-energy spark (Photo 30). In this case, a clamp (p-clamp) was omitted during assembly, which allowed the B+ cable to dangle enough so it contacted a structural gusset creating arcing (Photo 31).

### **Chassis Components**

Some trucks with hydraulic brakes use an emergency brake booster, which is powered by an electrical motor (Figure 9). This system intends to provide boost assistance to the brakes during an engine stall. Without this system, the operator would not be able to provide enough force, by his or her foot, to stop the truck. This system is wired to battery power. It is powered all of the time, regardless of ignition switch's position. Consequently, this can become an ignition source even when the engine is off and has been parked for some time.

### **Vocational Components**

Vocational components and systems are used to perform the vehicle's intended task. For example, a fuel truck may need to pump fuel from its tank to the intended storage tank of the customer. Many failure modes of the overall system can create either an ignition source or provide the release of the combustible materials. Photograph 32 shows the failure of a fuel delivery elbow, mounted to the tractor, used to distribute gasoline by a chassis mounted pump. Post-accident forensic test methods were used to recreate the fuel's release. This group of facts developed into an airborne combustible particulate ingestion and "back fire" fire.

### **Additional Ignition Sources**

Additional body-related ignition sources are:

- evaporator motor(s);
- condenser motor(s);
- defroster motor(s);
- A/C compressor clutch coil/wires;
- radio;
- GPS systems;
- dashboard wiring;
- air dryer heater wire;
- headlight wiring;
- air conditioning, high/low pressure switch wiring;

typically carries a ground signal (can usually be ruled out as an ignition source);

•ABS signal wiring; typically carries an inductive low voltage (milivolts) signal to the ABS controller (can usually be ruled out as an ignition source);

•engine-starting aids (starting fluid canisters) (Photos 33, 34).

These systems must be inspected periodically for proper wire/cable routing and support along with proper



*Photo 29: Example of "balling" phenomenon.*

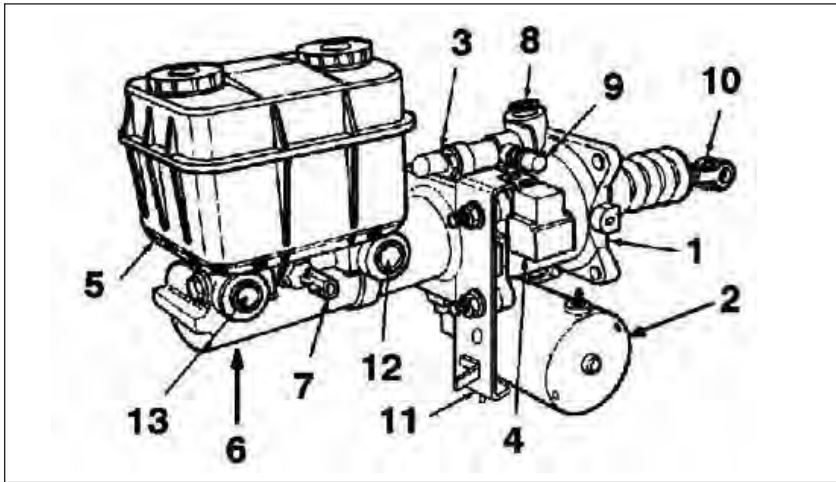

*Photo 30: B+ cable contacting structural gusset, creating B+ to ground.*



*Photo 31: B+ cable with "vee" cut from arcing (same cable as in Photo 30).*

## Figure 9 Electrical Backup Brake Booster (Motor Is Item #2)



(B+) connections and wire insulation. Usually not a leading fire cause, they must be as vigilantly inspected as any other component on the vehicle.

### CONCLUSION

This article assists investigators in conducting fire cause and origin analysis of heavy truck and equipment fires as well as shows the mechanical fingerprints associated with it. Additionally, once the correct cause and origin are established, manufacturers may elect to change system/design to prevent future fires. ☺

### REFERENCES

- Detroit Diesel Corp.. S-60 burst logic safety recall (NHSTA-06E-19, DDC:06C-4).
- Detroit Diesel Corp. Introducing the new 2007 series-60, 6SA2000 (0604), PT3M, 6SA2004 (0603).
- Ferrone, C.W. & Sinkovits, C. (2005, Nov.). The runaway diesel: A side-by-side mechanical analysis. ASME Paper No. IMECE 2005-79034.
- Ferrone, C.W. & Sinkovits, C. (2006, Nov.). Fire and explosion investigations: Why heavy trucks may burn. ASME Paper No. IMECE 2006-13305.
- Author's Note:** Photographs 15, 18 and 23 were supplied by International Electronic Machines, Corp. These photographs were taken using the SIRIS™ Smart Infrared Inspection System.
- Christopher Ferrone** is senior mechanical engineer at ARCCA Inc. in Chicago, IL. He may be contacted at (312) 386-2300; [cferrone@arcca.com](mailto:cferrone@arcca.com).
- Reprinted with permission from the Proceedings of IMECE 2009-10522, 2009 ASME International Mechanical Engineering Congress and Exposition, Nov. 13-19, 2009, Lake Buena Vista, FL. Copyright © 2009 ASME.



Photo 32: Full-scale testing of fuel breach.



Photo 33: Starting fluid canister shows impact damage.



Photo 34: Starting fluid canister (breached).